

1. Description:

Pneumatic controller with calibrated set value adjustment and fixed proportional range (approx. 3°C) for temperature control on the basis of the rod extension principle.

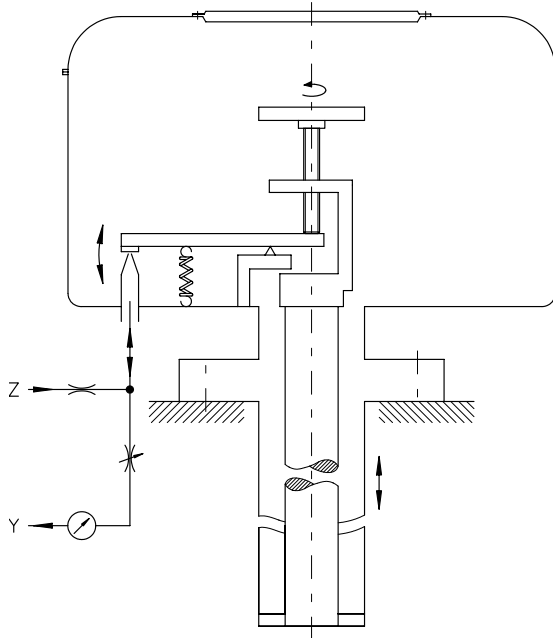

TYP 05076-2

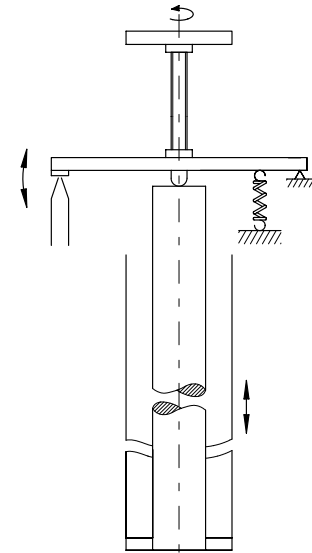

TYP 05075-2

2. Putting into operation:

- 2.1 The temperature controller is mounted at an accessible place, where the temperature has to be kept constant. Mounting position optional. **2/3** of the feeler rod shall at least immerse in the flowing medium.
- 2.2 On putting into operation the required supply air pressure of at least 1.4 bar (max. 1.8 bar) is adjusted at the air pressure reducer. The supply air pressure should be approx. 0.2 bar higher than the max. control pressure of the connected control valve (see nameplate: control range).
- 2.3 By turning the setpoint scale below and above the actual temperature it has to be examined, if the control device travels through the whole range (e.g. stroke of a control valve). If the required output pressure is not obtained, you have to test
 - a) the air connections for leakage points,
 - b) the constant restrictor for dirt.

Then the controller is adjusted to the requested set temperature (see operating instructions). In case that set value and actual value do not correspond on built-up condition of the control circuit, the setpoint scale can be recalibrated to the correct value.

3. Function:

3.1 By the connection **Z** the controller is supplied with control air (free of dust, oil and water) with a constant pressure of 1.4 bar (max. 1.8 bar). The connection **Y** is connected with the diaphragm control valve or similar control device. The control air blows on a nozzle/flapper system which is mounted to a lever.

The constant restrictor in the supply air line doses the air quantity in such a way that with open nozzle the pressure coming up at connection **Y** goes towards Zero and with closed nozzle towards 1.4 bar (max. 1.8 bar).

3.2 At the other end of the lever a feeler rod is mounted. A spring holds the lever in its bearing. The sensing element consists of a pressure rod with very little thermal expansion and a feeler tube with high thermal expansion.

3.3 With type 05076-2 the pressure rod draws the lever downwards on increasing temperature so that the gap of the nozzle/flapper opens on the other side and the output pressure drops (action: increasing/decreasing).

3.4 With the type 05075-2 the output pressure **Y** increases with increasing temperature because of the different construction of the lever (action: increasing/increasing).

3.5 The setpoint scale makes a change of the set value possible in the range of 0-100°C. For exact description of the adjustment procedure see operating instructions. In the output of the controller there is a damping restrictor which has to be adjusted once on the site, by which the control speed of the control valve can be influenced in case of a slight vibration tendency of the control circuit.

4. Service and Operating Instructions:

4.1 Adjustment of the setpoint scale:

The two screws of the cover are loosened and the cover removed. Then the setpoint scale is adjusted to the requested temperature. Reference point is the red marked pin.

4.2 With type 05076-2 the pressure drops on turning the scale clockwise (adjusting of a lower temperature) and the actual temperature must drop in order to regain the old pressure.

4.3 With type 05075-2 the pressure increases on clockwise turning and the temperature must decrease in order to regain the old temperature.

5. Maintenance:

The constant restrictor should be removed and cleaned by experienced personnel, e.g. fine mechanic, at larger intervals (dependent on the air quality).

Further data concerning the temperature controller type 910:

DS 910
910-AN
910-TB