

# ARCAristics

CUSTOMER MAGAZINE FOR LEADING CONTROL TECHNOLOGY 04.2022

## ARCA FLOW GROUP: THE HEART OF YOUR PROCESS

### FELUWA Pumpen GmbH

Specialist in high-quality pumps for conveying aggressive and abrasive media as well as media containing solids

### Joint ventures & branch offices

in Europe, America, Asia, Africa, Australia

### ARCA Regler GmbH

Specialist in sophisticated industrial process control valves

### WEKA AG

Specialist in cryogenic components, special valves and level measurement technology

### ARTES Valve & Service GmbH

Specialist manufacturer of customer-specific desuperheaters and control ball valves

### von Rohr Armaturen AG & Von Rohr ARCA BV

Specialist manufacturer for precise valves and actuators for the selected process industry



# PROLOGUE

“Everything must change, so that everything can stay the same.” What the Italian writer and literary scholar *Giuseppe Tomasi di Lampedusa* (\* 23. December 1896; † 23. July 1957) realized from his observations on the processes of change, is covered with our attitude and our actions. Keeping this in mind, we have not only redesigned our customer magazine ARCAristics for control and process technology, but rather also added more information. Along with exciting references, the magazine includes a special range of services. More interaction is also important in our new edition.

Various QR-codes offer links to websites, videos and 3D animations of our control valves. Of course, we did not forget contact data to your direct contact person.

We hope you enjoy reading!



# CONTENTS

FOREWORD .....	02
CONTENTS .....	03
ENGINEERING EXCELLENCE 2022 .....	04
<b>ARCA REGLER GMBH</b>	
The Blue Shepherd from Tönisvorst .....	06
Control the flow – control the DIAM .....	07
Always on site at chemical parks .....	08
The control army from Shandong .....	09
Operation Dead Zone .....	10
High Performance Test passed .....	11
Is everything flowing? .....	12
The Control Giant from Duisburg .....	13
Giga Valve for Giga Steel Mill .....	15
<b>ARTES VALVE &amp; SERVICE GMBH</b>	
High-end for the energetic transformation .....	16
<b>FELUWA PUMPEN GMBH</b>	
From Idea to Prototype in just a few hours .....	18
Size does matter .....	19
Digital Days – 24/7 closer to our customers .....	20
<b>VON ROHR ARMATUREN AG</b>	
Thinking around corners .....	21
<b>WEKA AG</b>	
Communication 4.0 .....	22
<b>OUTLOOKS</b>	
Next Level Engineering .....	24
<b>ARCA FLOW GROUP<sub>w</sub>-TEAM</b>	
One for all, all for one .....	26



ENGINEERING  
EXCELLENCE  
2022



## ARCA-TECHNOLOGY: CENTERPIECE FOR SAFE AND EFFICIENT PROCESS CONTROL

2022 is the year in which the ARCA Flow Group would like to put technology, service and visibility in the market front and center. We want to underscore our standards for technological market leadership in sophisticated control solutions with even more focus on the customer and the expertise of a network of specialists. We have known for years that nowadays *Engineering Excellence* requires a great deal more than just design skills. Our network is a response to the increasing complexity and the meshing of many fields of application in processes. The ARCA Flow Group reflects that with expertise in measurement technology and conveyor and control technology.

Such a networking of knowledge and experience brings enormous advantages for you and your processes. Thanks to the high degree of digitization of the ARCA Flow Group, the accumulated knowledge of several applications for a wide variety of branches flows into each running project. The valve history stored in the ERP system can furnish us with comprehensive information about the wear of important components. Failures can be better calculated and predicted, and then prevented.

Our pursuit of *Excellence* is also reflected in our range of services. Because a plant without good maintenance, be it by your own trained personnel, by valve experts like us, is a risk that can be avoided. Our contracts increase security and efficiency and are tailored precisely to your plant. All this has a demonstrably positive effect on reliability and life-cycle costs. Ask about our empirical values and a sample calculation.

At the ARCA Flow Group, the networking of knowledge is an important component of the foundation of good control solutions. The different types of expertise flow together, both digitally and virtually as well as in reality. Our group-intern technician days, which we have been hosting since 2019 in our Research and Innovation Center, demonstrate this.



© Adobe Stock

# THE BLUE SHEPHERD FROM TÖNISVORST



At the celebration of the 80th birthday of company owner *Dr. Ing. Rüdiger Kaspers* in December of 2021 there were some unexpected additions

6 blue sheep of object artist *Rainer Bonk* were presented to the proprietor of ARCA Regler GmbH. Each sheep is a symbol of a member of the ARCA Flow Group. Together, in charismatic blue, the sheep stand for tolerance and the interaction beyond all ethnological, religious or cultural differences. The herd illustrates the appreciation of the other by equality.

The certificate presented to *Dr. Ing. Rüdiger Kaspers* has further appropriate words: "We are all equal – everyone is important. Blue stands for unity, trust and freedom. It is the color of the European Union, of the United Nations and of ARCA. Blue stands for human interaction and of course also for the network."



The blue sheep of the artist *Rainer Bonk* now peacefully graze on the Tönisvorster greenery. For years, the project "Blue Herd" has also been under the auspices of the European Union Parliament in Strasbourg and Brussels. More information at [www.der-blauschaefer.de](http://www.der-blauschaefer.de)





# CONTROL THE FLOW – CONTROL THE DIAM

First entry in new design with increased commitment – a look back at the DIAM in Bochum

After a long absence, in October of 2021 ARCA made its formal return to physical presence on an exhibition. Although the German Trade Fair for Industrial Valves took place in the Jahrhundert Hall in Bochum under Covid19 conditions – limited attendance, 3G rule (vaccinated, recovered or tested), extensive hygiene concept – the 10,000 m<sup>2</sup> exhibition area with 130 exhibitors from the valve and sealing industry and 1,600 visitors brought true joy into the hearts of ARCA Regler GmbH and the visitors.

In spite of attendance figures down by around 30 % (compared to 2019) the trade fair was a complete success. On 75 m<sup>2</sup> the ARCA was not only significantly larger, but rather also had a much larger presence due to the new image with completely reworked corporate design, new product videos and the motto CONTROL THE FLOW.

Next to the booth design there were additional eyecatchers: the 12" ECOTROL® single seat control valve 6H8-L3 as a compressor bypass valve, the POWERTROL steam conditioning valve, many different variations of the ECOTROL®, the FORGEVENT, the ARTES desuperheaters and the von Rohr bottom outlet valves. Due to the conditions the number of employees at the booth was limited.



With the core message *Engineering Excellence* since 1917 visitors gazed in amazement at ARCA's new dynamic image. Lots of technology, lots of emotion and strong communication were keys to the success of the trade fair. (Motifs below: © DIAM 2021)

However, our installed touchscreen monitors gave visitors the opportunity to chat with employees from the home office. In addition, other monitors showed the new product videos of ECOTROL® and POWERTROL.

Our conclusion: In spite of worse conditions than 2019 we were able to greet more visitors and conducted many interesting conversations. The DIAM 2021 was a complete success!



# ALWAYS ON SITE AT CHEMICAL PARKS



The workshop of *INEOS Manufacturing Deutschland GmbH* has 40 employees, of these 10 in the field of control valves with their own test bench up to DN 250 PN 630 with SAP connection. The team repairs about 2,000 valves a year.

## New qualification concept for authorized workshops of chemical parks

The number of ARCA valves used in chemical parks is steadily increasing. As a result, inquiries are rising significantly, in particular spare part requests. This is accompanied by the wish of operators for short reaction times, the availability of spare parts and minimization of down-times. Regular maintenance of plants and valves have the highest priority at chemical parks against the background of ensuring the plant function.

The valve workshops located in the chemical parks not only have the local "home advantage", but also an extensive knowledge of the plant situation, including the plant and local regulations. Therefore, the ARCA has decided to cooperate with the workshops located in the chemical parks and contribute to their qualification. In cooperation with sales, product management and quality management, the ARCA service department has developed a qualification concept which not only encompasses the training of the workshop employees, but also includes other conditions on site. The following are considered and evaluated: workshop equipment (measuring equipment, machining tools and much more), possibilities of the test bench,

inspection of the workstations and the documentation of the valve histories.

On this basis, the valve workshop of *INEOS Manufacturing Deutschland GmbH* was named the second authorized ARCA workshop in March 2021. On an area of 200 hectares 4 million tons of chemical raw materials are produced per year by a total of 2,500 employees.

From October 2021 to January 2022 three other workshops were trained by ARCA, which among other things, work for BASF. The employees received instruction in the use, maintenance, modification and damage analysis of ARCA valves of the ECOTROL® series. Further training and certifications are already in process or planned for this year. Thus, we also offer our customers the desired support for the future security of their plant and meet high quantitative and qualitative requirements for your plants in all ranges.

If you are interested in **training** and **certification** please contact:

**Markus Spranke:**  
(Specialist for  
Repair & Service)





# THE CONTROL ARMY FROM SHANDONG

124 valves with special bellows seal for corrosive and toxic media for China

The client belongs to the *Xinfa-Group*, which, with 60,000 employees is the number 1 of the top 100 private enterprises in the province of Shandong. The valves are installed in a world-scale plant for manufacturing PVC (polyvinyl chloride). Due to its properties, this plastic is used for garden furniture, window frames or also as a building material (floor surfaces or pipes/cable sheathing).

The special feature of the 124 valves is the bellows seal made of Hastelloy®, which is used due to the corrosive and toxic medium (HCl gas), in order to ensure that “no leakage” occurs in the spindle movement of the valve. In general, a bellows seal is used to maintain clean air or for the reduction of emissions of air pollutants from plants subject to licensing. This also includes highly toxic, radioactive and highly corrosive media applications.

ARCA Regler is working closely with ARCA Flow Technology (Shanghai) Co. LTD in this project. This powerful duo ensured the punctual delivery of the valves to Shandong during the Pandemic. The duo also managed to win the contract after the call for tenders among a number of first-class, international competitors. Shandong!

6N4-P1 ECOTROL® series  
DN 200 PN 40  
Media-wetted surfaces  
1.4408/1.4571  
Bellows Hastelloy® C276  
Leakage rate class V





# OPERATION DEAD BAND

In the limit range and in the event of disturbances you can rely on our anti-surge valves

*Anti-Surge Valves (ASV)* meet the most stringent requirements and in the event of disturbances must open fast as lightning, with precise positioning and absolute reliability. ASV-valves are used for example with axial compressors in the steel industry. One of the world's leading compressor manufacturers has decided to use our valves and commissioned three control valves for the compressor stations of a steel mill at Kaohsiung in Taiwan.

The ECOTROL® control valves in the nominal size of 16 inches are used to secure the compressor for the wind blower to supply air to the blast furnaces. There an air supply of between 4 and 5 bars is required in order to achieve sufficiently high temperatures for combustion in the blast furnace. If during this process there should be an increase in pressure on the consumer side, a return flow will occur in fractions of a second. For the compressor, this means that the pressure will abruptly increase. The consequence would be backflow and flow interruption, so that the compressor accelerates (overspeed) due to this cyclical action (pumping).

The consequences would be dramatic. There is a danger of damage to the machine blades, all the way to severe potential total machine loss. To prevent this, the hydraulically controlled valves must react in less than one second in the event of a fast-acting trip. This means opening in < 1.5 sec max. dead time of < 100 ms – at very high volumetric flow rate and the most stringent requirements on the control performance. A highly demanding task, where there is no second chance. Our technology convinced them.

Thanks to our years of experience with compressor valves and our competence in the steel industry, steel production in Taiwan is now also safely regulated.

Three hydraulically controlled valves of the ECOTROL® 6N type, nominal size 16" 600 lbs., which open in the event of a fast-acting trip via a solenoid valve in < 1.5 sec at a max. dead time of < 100 ms.



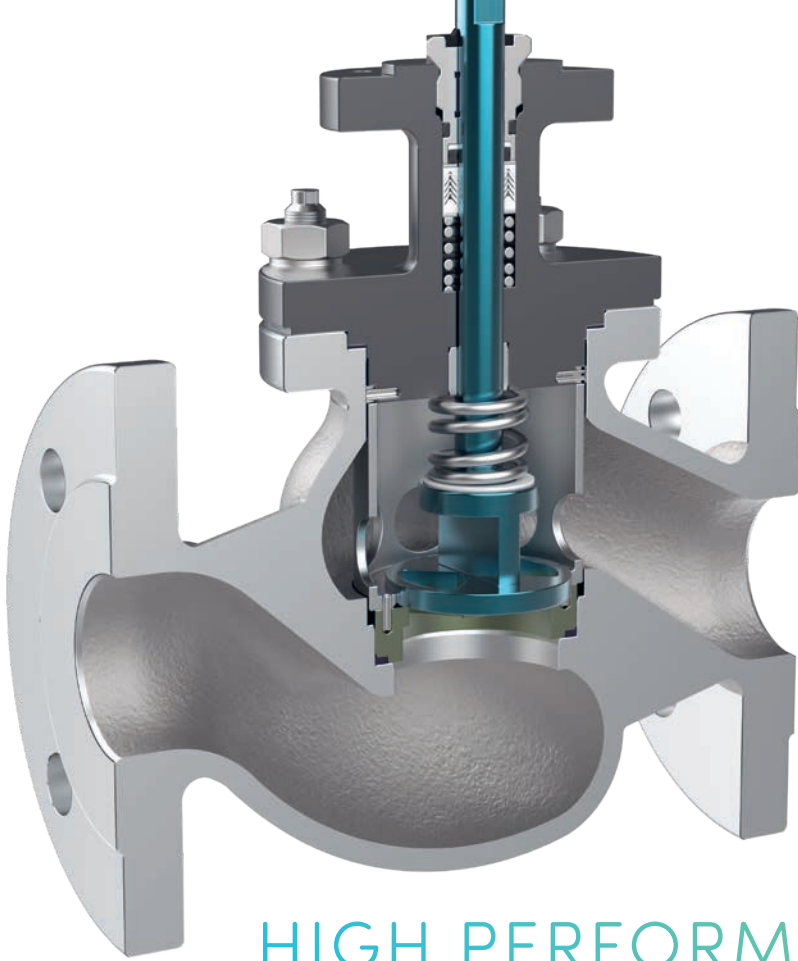

The special challenge: To upscale the present ECOTROL® rotary gate valve from Kvs 4.5 m<sup>3</sup>/h to the nominal size DN 80 and Kvs 63. The existing specifications of the disks could not represent the required kv values; therefore, a new geometry of the disks was designed, with which the valve is now available for delivery in DN 80 Kvs 63 lin/ Kvs 40 =%..

You will find more control technology in steel mills here::

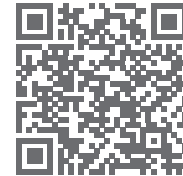

## HIGH PERFORMANCE-TEST PASSED

### The further development of the ECOTROL® rotary gate valve in the customer's load test

There can be extreme conditions in steel mills – this is also the case with this project: Molten steel is solidified using the continuous casting process, with the aid of a water-cooled copper mold. In the following secondary cooling the strand, supported by a continuous water cooling, is completely solidified. Depending on the casting width, this cooling is automatically regulated via individual cooling zones, which are fed with water by means of separate control valves for targeted cooling. Therefore, producing high-value steel qualities requires a wide variety of water supply.

The required control valves must fulfill extremely high resolutions and range-abilities.

To meet these extraordinary requirements, a new supplier was sought at an internationally operating German company in the field of iron works and rolling mill technology. The ARCA and its valve technology embraced this challenge on the valve performance test bench of the customer. The required rangeability of at least 1:100 could not be realized with a classic parabolic plug. The customer was provided with a further developed Kvs 4.5 m<sup>3</sup>/h, DN 25 rotary gate valve to measure the Kv value characteristic versus the valve position. With a very high sample rate, valve position-actual value, valve position-setpoint, water volume flow and pressure P1 & P2 were recorded with the Kv values calculated from the data.

Our ECOTROL® rotary gate valve was able to meet the requirements with very slight deviations between valve position-actual value and valve position-setpoint to the customer's complete satisfaction and was qualified by our customer for this highly demanding application.

With this further product development, in the future we will be able to regulate the smallest Kv values near the closing region at a rangeability of over 1:100 in valve size up to DN 80 and supply a further variant of the ECOTROL® series to our customers.



# IS EVERYTHING FLOWING?

DO YOU HAVE ANY QUESTIONS?  
WE KNOW ANSWERS!  
TEST OUR SOFT SKILLS THESE  
THREE WEEKS:



**23-27/5**  
TRAININGS  
**15-19/8**  
PLANT CHECK  
**07-11/11**  
MAINTENANCE  
CONTRACT

## Get advice without obligations!

How do I optimize my process?  
How do I improve plant safety without my costs going through the roof?  
Are there solutions for switching to hydrogen?  
How do I save resources through smart regulations?

## Our contact persons:

Markus Spranke

Andreas Rinsch

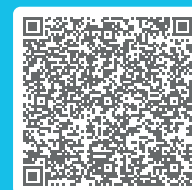

### Training\*

Our inhouse technician training brings your employees up to speed on control technology and gives important maintenance tips. Inquire with our service for more detailed information about this one-day training session in Tönisvorst. Free of charge for every second employee.

### Plant check\*

Our service personnel will visit your plant free of charge on site or online by monitoring. We check the characteristics and performance parameters of your plant for abnormalities (impending wear or failure) and if necessary optimize the "running conditions".

### Maintenance contract\*

We will extend your maintenance contract by 12 months free of charge or activate it for a year free of charge, if you don't yet have a maintenance contract for your control valves.

\* The offers are valid as long as appointments are available. Only available in Germany.

Series: 6N  
(with pressure relieved trim and  
1-step piston plug)  
Dimensions: 24" ANSI 300  
Housing material: stainless steel  
Actuator: pneumatic

A control valve more than four  
meter tall for *Siemens Energy*  
in Duisburg breaks the internal  
design height record of ARCA

In September 2021 there was a special type of acceptance test at our location in Tönisvorst. With a design height of 4.20 m, we succeeded in proving ourselves once again as first contact partner in the field of compressor construction by the production of our "control giant".

This record was achieved by the pairing of a 24" valve with a special bonnet, which in addition to its conventional components, also includes a bellows seal (DEK4). This seal is specially designed to prevent any emission of the medium through the stuffing box. Due to the exorbitant design height, it was necessary to switch to alternative assembly steps, which enabled us to manufacture the valve according to customer requirements.

Along with this colossus, this project from *Siemens Energy* likewise included a 20" valve and a 62" perforated disc. *Siemens Energy* requires these valve components for a plant of their customer *Formosa Petrochemical Group*, which is to be built in the east Chinese coastal city of Ningbo. The control valve is part of a delivery of a gear type turbo compressor train, which will be used in a purified terephthalic acid plant (PTA) to manufacture plastic products. The compressor train consists of a gear type compressor of the STC-GV (200-4) type and a cold gas expander STC-GT (160-2), which are driven by an electromotor.



# THE CONTROL GIANT FROM DUISBURG



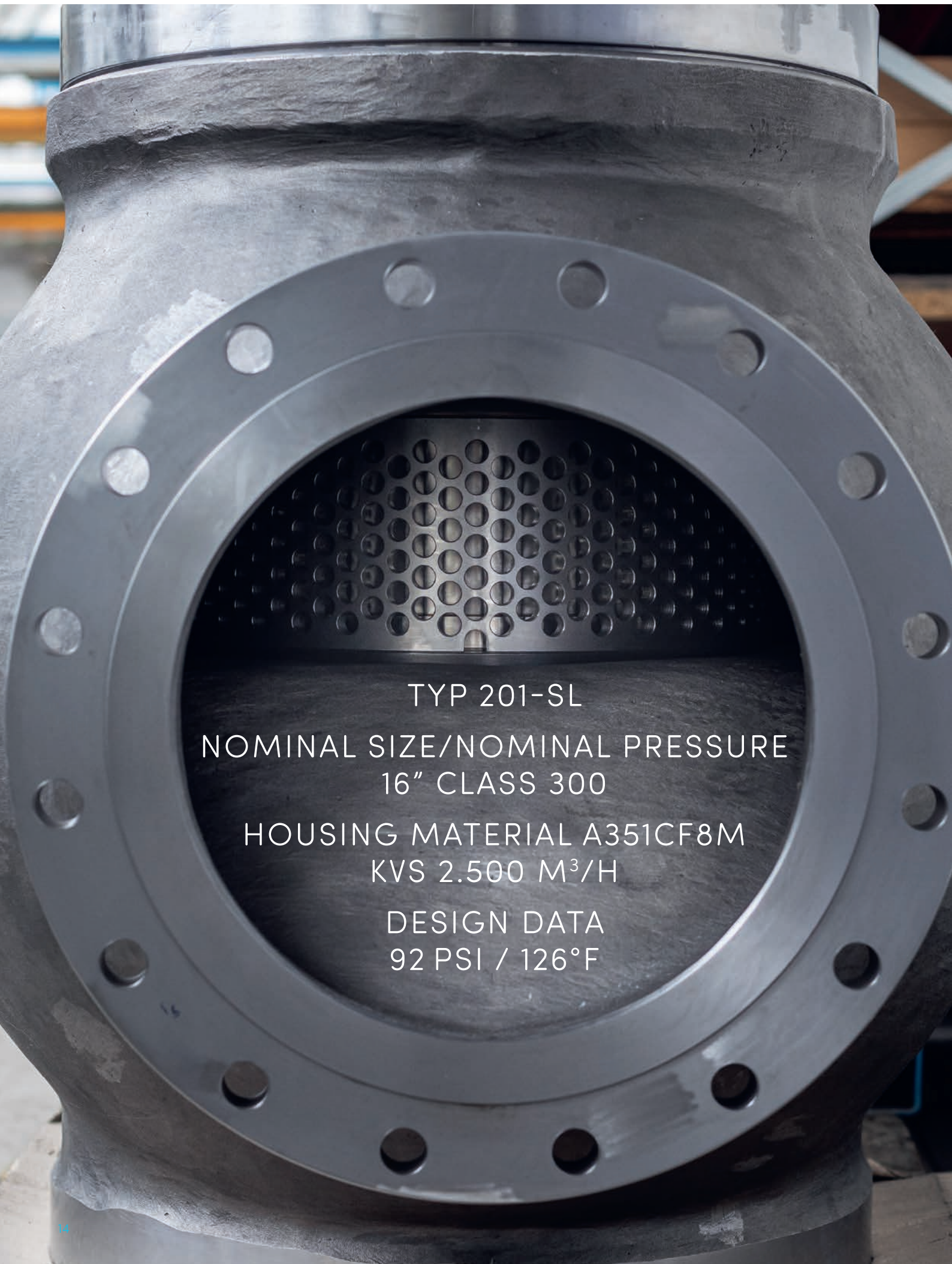

TYP 201-SL  
NOMINAL SIZE/NOMINAL PRESSURE  
16" CLASS 300  
HOUSING MATERIAL A351CF8M  
KVS 2.500 M<sup>3</sup>/H  
DESIGN DATA  
92 PSI / 126°F



# GIGA VALVES FOR GIGA STEEL MILL

Two gigantic valves control the cooling of an electro-steel plant for a Gigafactory

Somehow, gigantism and Tesla belong together. This is confirmed by the order of our subsidiary, *ARCA Flow Controls* in the USA. The challenge there was to construct enormous control valve sizes for a gigantic new steel mill.

*Steel Dynamics*, an American steel manufacturer, is building this steel mill for 1.7 billion US dollars in Sinton, in southwestern Texas. The company builds exclusively electro-steel plants, in which steel is produced in an electric arc furnace or crucible induction furnace at 1,500 to 1,800 °C out of recycled raw materials (mostly scrap). Once completed, the plant is supposed to produce around 3 million tons of steel per year.

The special feature of these valves lies in the large nominal size with simultaneous precision in the targeted cooling of the steel, which occurs through the mixture of warm and cold water. A technical challenge, which only few valve manufactures want or are able to manage, but which was supplied by our US subsidiary, *ARCA Flow Controls*: in the form of two 16" ANSI 300 valves. By clever design approaches *ARCA* was able to offer the client a convincing solution, rapidly and flexibly. *ARCA* won out against national and international competitors.

The location of the new steel mill is not far from Tesla's new Gigafactory 5 in Texas. The plant will supply the steel for the production of the iconic cybertruck. The vehicle is a pick-up truck, whose body consists largely of 30X stainless steel.



30X stainless steel is an optical code of Tesla's iconic cyber-truck. (Image courtesy of Tesla, Inc.©)



These two enormous 16" ANSI 300 3-way valves regulate the temperatures in the steel production of the new electro-steel plant in Sinton (Texas).

# HIGH-END FOR A CLIMATE-FRIENDLY ENERGY MIX

## Endurance test on energy transition and required capacities of 23 gigawatts

Huge challenges await politicians and businesses world-wide to effectively limit global warming. Energy conversion from gas will play a meaningful role getting there, and will continue to do so for a long time. The German business newspaper "Handelsblatt" reported on calculations carried-out by the *Energy Economics Institute (EWI)* at the University of Cologne. Thus, gas-fired power plants with an installed capacity of 23 gigawatts will have to be built by 2030. A performance that, purely in mathematical terms, corresponds to that of 23 nuclear power plants. The Federal Network Agency currently lists 2.3 gigawatts of gas power plant capacities up to 2023 as a planned expansion. So high-end fittings for the climate-friendly energy mix are definitely needed.

## Valve Endurance Test

The extraction, distribution and processing of gas as an energy source requires a perfectly constructed and functioning technical infrastructure, exactly what the industrial valves from ARTES Valve & Service GmbH are suited to. An order for a natural gas pipeline within the EU, delivered in 2021 using control ball valves, ensures maintenance-free operation of the installation.

The ARTES characterized control ball valves not only operate the switching states "OPEN" and "CLOSED", but can also be regulated in their task as a control valve in the entire setting range from 0 to 90 degrees, furthermore bi-directional operation of the valve is also possible. In addition to the established linear and equal percentage rule characteristics, ARTES also uses specially designed regulating discs that are precisely customized to the customer's application. Should the control characteristics requirements change during operation, simply exchange the control disks to suit the new medium.

Multi-stage regulated pressure reductions can also be implemented in order to minimize noise emissions or to reduce wear. ARTES has a patented solution and thus offers a decisive competitive advantage.

Possible working states of the ARTES characterized control valve.

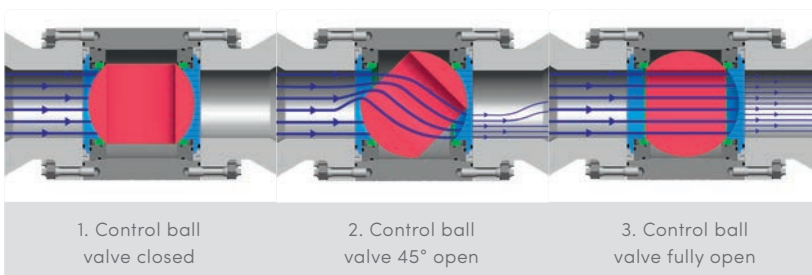



Ready for delivery:  
32-inch characterized  
control valve type G with  
regulating disc and drive.

Digital brochure from  
ARTES – view directly  
with the QR code:

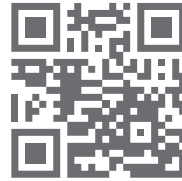

### Control ball valves – metal-sealing fittings

This is achieved using a combination of ball and seat ring. Both components are made of stainless steel and then coated. The application-specific use of the Wolfram coating materials or chrome carbide creates highly wear-resistant surfaces with a Vickers hardness of up to 1400 HV. After the coating, the components can only be machined with diamond tools.

In order to achieve a gas-tight closing of the valve, the seat ring and ball are ground in pairs with diamond lapping paste. When used in natural gas applications, the fittings are considered maintenance-free.

The control ball is trunnion-mounted, permanently sealed to the outside and can be driven with an actuator according to DIN / ISO 5211. The connections are designed for use on either welded or flange ends. DN 25 to DN 800, in the nominal pressure levels PN16 to PN420, can be ordered as nominal widths – individual requests on enquiry.

### A very successful year for ARTES

The year 2021 was one of the most successful in ARTES' corporate history. Managing Director Horst Jäkel is particularly proud of the manufacturer-independent service that the company offers. There are framework agreements with large energy concerns that reach far into the future. The product range has proven to be absolutely competitive, which is reflected in a very good order situation.



# FROM IDEA TO PROTOTYPE IN JUST A FEW HOURS

FELUWA relies on the use of modern 3D printing systems for small batch sizes (as of 1)

For this purpose, FELUWA's in-house technical centre was expanded by the addition of a 3D printer. The components are printed using the *Fused Layer Modelling* (FLM) process. In the FLM process, a plastic thread, the "filament", is conveyed through a heating system to a nozzle, where it is melted. The molten material is applied layer by layer through the nozzle to create the component.

The manufacturing process demonstrates its main strengths in its geometric freedom and speed with small batch sizes. When developing prototypes, it opens up new possibilities by not only displaying the components digitally, but also allowing them to be physically handled. Functional models are already being realised as well.

The inner contour of the retainer was developed and optimised in its hydraulic design as part of a CFD parameter study before being produced by 3D printing.

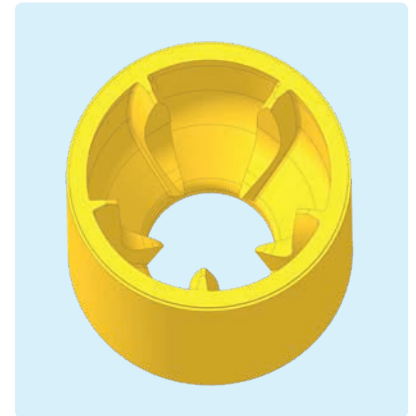
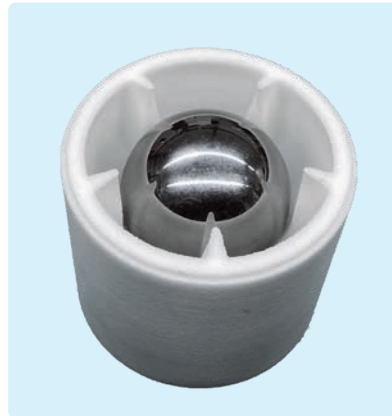

For example, FELUWA printed rubber-elastic spokes for a new type of check valve, which saved valuable time in the early development phase. In the subsequent long-term test within the test pump, the printed components performed convincingly. Possibilities are particularly impressive with the self-printed retainers. Once the design was complete, the data was sent directly to the 3D printer. The prototypes were created overnight, allowing for the test run with the new components to be started the very next morning.

A process that would otherwise take days, weeks or even months can be implemented in hours, which is particularly appealing for new developments. FELUWA is currently looking at how 3D printers can support the daily development and production process.



FELUWA's 3D printer using FLM process.

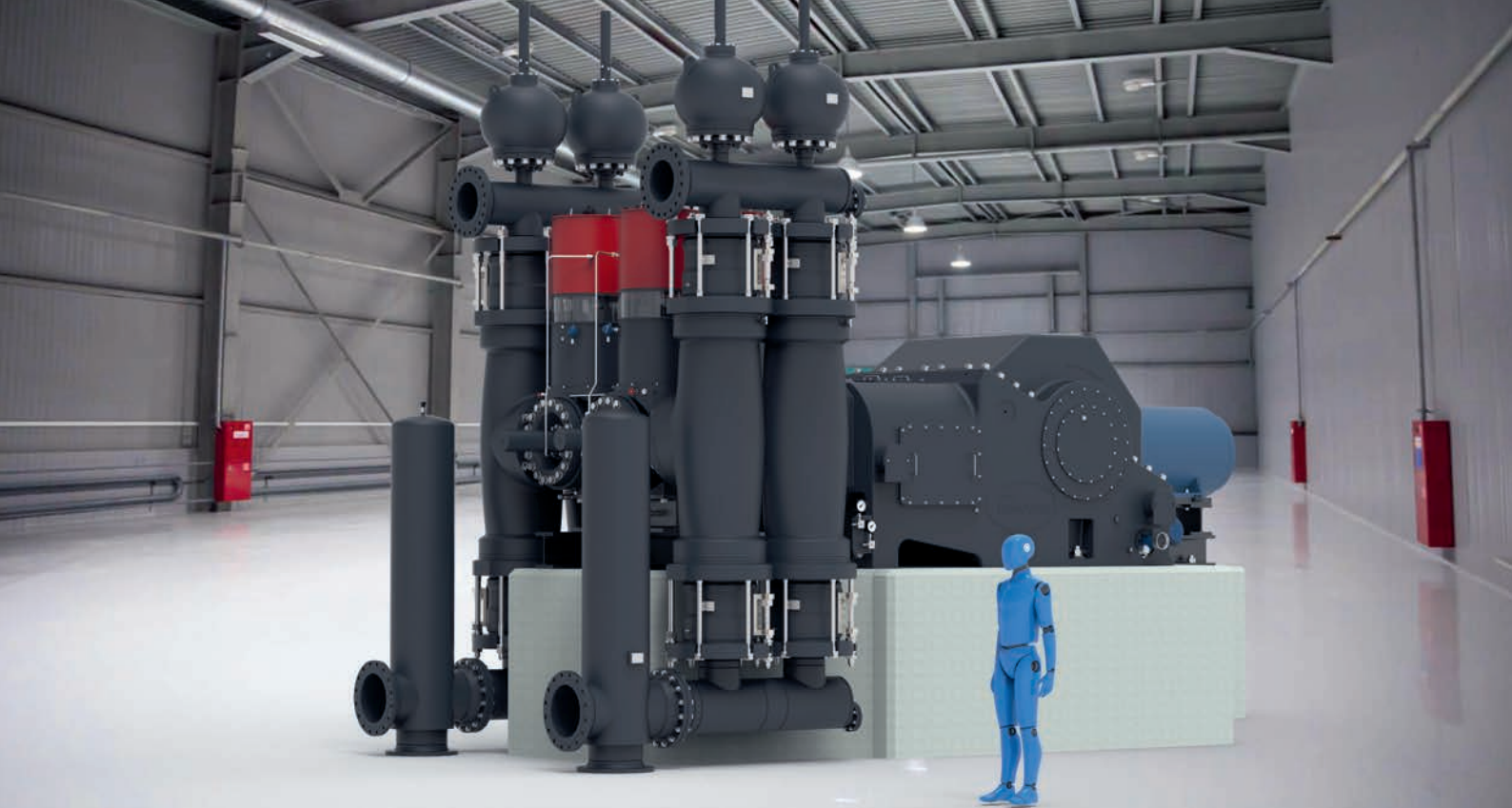

# SIZE DOES MATTER

10,000 bathtub volumes per hour, from the sea to the summit of Zugspitze mountain – effortlessly handled by our DGK 500 pump

Already, FELUWA offers the most comprehensive product portfolio in the field of diaphragm piston pumps. FELUWA is meeting the globally apparent trend towards large-volume pumps in medium pressure stages with the development of the new DGK 500 stroke gear. It is a double-acting gearbox that delivers with both the forward and return strokes. This design is ideally suited for low and medium pressure applications.

Equipped with DS350 MULTISAFE® pump heads, a volume flow of up to 800 m<sup>3</sup>/h can be achieved. The bathtub chart impressively illustrates the comparison of volumes.

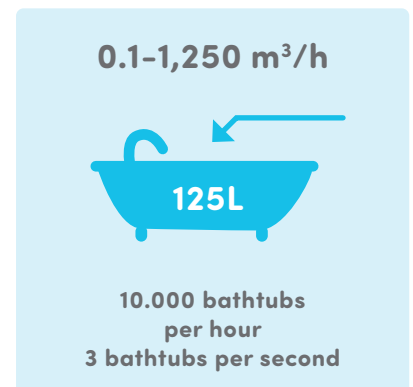
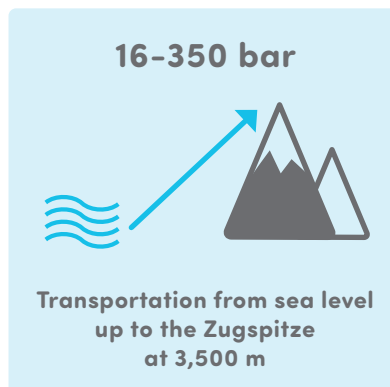

In addition, the DG250 gearbox, which has been in successful use for more than 30 years, was revised. The maximum drive capacity of the new DGK250 is now 415 kW. As a result, the new gearbox offers 42% more power than the discontinued DG250.

Due to new manufacturing processes and a new type of crank shaft design, the manufacturing costs could be reduced despite the increase in power. All newly developed stroke gears follow ARCA Group's idea of standardisation and modularisation, so that optional components such as redundant oil pump and heating etc. can also be retro-fitted without the need for reworking.



# DIGITAL DAYS – CLOSER TO THE CLIENTS 24/7

How FELUWA maintains and intensifies digital contact to the clients

In terms of FELUWA's communication, the past two years led to new digital channels, formats, topics and offers. Our worldwide representations played a particularly important role in this. In order to provide them with interesting technical innovations and to communicate the unique selling points of the FELUWA MULTISAFE® double hose-diaphragm pumps, the FELUWA sales team launched a webinar series for our international sales partners.

To help customers, partners and interested parties find their way to the right pump technology even under difficult conditions, the Star Pump Alliance hosted the Digital Days for the first time in 2021. The two-day free digital event of the pump industry was a combination of conference and trade fair.

In their presentation, our Regional Sales Managers explained how to discover the full cost-saving potential of diaphragm pumps. Furthermore, the FELUWA explanatory video series was also continued on YouTube with a video about the smaller MULTISAFE® pumps. With this, we are closer to our worldwide clients – online and 24/7.



Uwe Arce explains the features and areas of application of two FELUWA "sales hits" on YouTube.





After we were asked to create a special bottom outlet valve for the PET industry last year, we received a challenging follow-up order this year. The special feature of this model is the 90° corner shape, which has never been realised before.

### To the bottom outlet valve for the PET industry

The around-the-corner shape differs from the classic bottom outlet valves, whose angle of connection is usually between 45° and 60°. The flow direction was also required in closing direction. Another special feature is the heating jacket design and the heated reactor flange. This “critical” point for the customer also required a flange design that maintains the temperature precisely to prevent the medium from solidifying.

The customizing of such sophisticated bottom outlet valves, from the virtual design up to series production, has become a successful business model for von Rohr Armaturen AG. In other words, expertise is also available for around-the-corner control solutions.

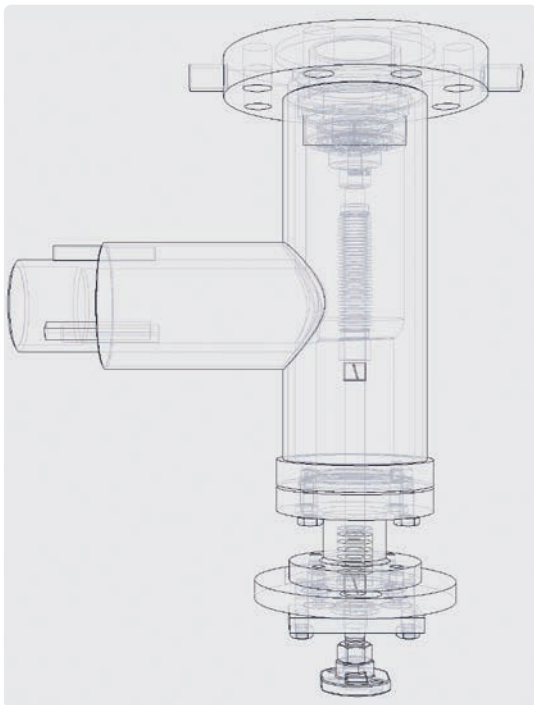

Around-the-corner design means targeted straight-ahead planning, here an early CAD design step to define the shape of the component corpus.



The realisation of the 90° corner shape is a novelty for the bottom outlet valve.

# THINKING AROUND CORNERS

# COMMUNICATION 4.0

**WEKA AG**  
525 Follower:innen  
1 Woche · 🌐

Crazy times all around.  
A look at our shipping volume confirms this.  
If we usually have an average shipping volume of 5,000kg, in October it was a whopping 9,000kg!!!!  
That is roughly equivalent to 12 well-fed Swiss pasture cows.  
That is impressive and we're curious to see if WEKA can beat that again this year.  
Either way, we are proud of our small logistics team and this great achievement.

Stay tuned...  
[#reliable](#) [#flexible](#) [#wekaag](#) [#levelmeasurement](#) [#cryogenics](#)

*how are things on the shipping front?*

**WEKA AG shipping volume october 2021**

👤 Jela Micanovic und 19 weitere Personen 2 Kommentare

👍 Gefällt mir    💬 Kommentar    ➦ Teilen    ✈️ Senden

Whoever talks about transformation in business, should not forget about transforming communication

WEKA has understood transformation and ushered in the era of Communication 4.0. We offer “users” and their fundamentally changed media usage behavior, which is also reflected in the B2B world - key words: digital, mobile, visual - a wide range of products and services.

That’s why our new communication and marketing strategy puts the customer at the heart of all our considerations. In the various phases of the “customer journey,” customers receive tailored information on different channels and platforms. With a language adapted to the respective medium. On social media channels such as Facebook, the factual tone and technical topics may be quietly exchanged for a more emotional and creative way of providing information.

Nuclear fusion research and its potentials:



The potential of hydrogen in the energy supply:





To the WEKA corporate film:



### Communicating in an increasingly “snackable” way

An important component of our new communications strategy is consistent content marketing: The content relevant to WEKA is weighted, managed and scheduled centrally in advance and then consistently adapted to the channels in question for the right “flow”, then played out. Subsequently evaluated with monitoring. On LinkedIn, too, we ensure the snackability of our messages in the form of compact and visually attractive information morsels. We prefer to place HR topics and events in this channel. In addition, the one or other adapted product topic also reaches an interested audience.

### Communicating visually

The current video productions of WEKA AG account for user needs: Our new corporate film shows how small WEKA components help to shape life’s big issues. Other videos make nuclear fusion research accessible or illustrate the role of hydrogen in energy supply.

### Digital and customer-focused

Our optimised website is an information hub for Communication 4.0 of WEKA AG. The website is visually appealing, of course optimised for “Mobile Devices” and now offers visitors a top-performance experience at all times, not to mention new key word indexing plus a built-in product search function. Additional benefits result in this respect:

Even without previous product-specific knowledge, customers will find the right solution in just a few moments. Of course, comprehensive documentation for each of our products can be downloaded.

### The future is 3D

During the course of the year, a CRM system will be created for our customers and will make it possible to process inquiries in an even more individual manner. Based on this, we will offer WEKA webinars with product training sessions not restricted in terms of time or place. Our Communication will become truly 4.0 with the planned 3D product applications, which are also for the sale and support of attractive tools – to increase the satisfaction of our customers once more.







# NEXT LEVEL ENGINE ERING

# WE ARE ON

Technological change is a challenge for the ARCA Flow Group that we embraced early on. Due to the systematic networking of the group, the knowledge of the network – from measurement and control technology, to conveyor technology to control and drive technology – run together in a “flow” for your project.

Another building block for the correct “flow” are our training programs. For example, the training programs of ARCA Regler GmbH in our Research and Innovation Center in Tönisvorst. Here your employees receiving training to bring them up to speed for the control and maintenance of plants. Just how far this can go, is shown by the report on page 8 with the qualification concept for authorized workshops of chemical parks.

We also achieve a new level with *Virtual Engineering* in the Design and Development Department. Innovative technology is employed not only for the hardware, but also for the simulation of flow patterns and process flows. Thus, we are already working today on virtual reflections of entire processes of tomorrow. This will further improve our monitoring, our diagnostics and our wear prognoses. As a result, plant safety would be raised to a new level. It is the dream of our engineers and the technical vision of ARCA to achieve the perfect “flow” virtually at the press of a button.

Therefore, we would like to expressly communicate our promise to CONTROL THE FLOW once more at the end of this customer magazines. Please contact us and we will show you what all the ARCA Flow Group can do for you today and tomorrow.

With our 3D simulations we are laying the foundations in order to support the fitters on site in the future and at all corners of the world in the maintenance and replacement of spare parts. Here you can see our POWERROL.

Currently we are working on the transformation of 3D data to augmented reality-applications.

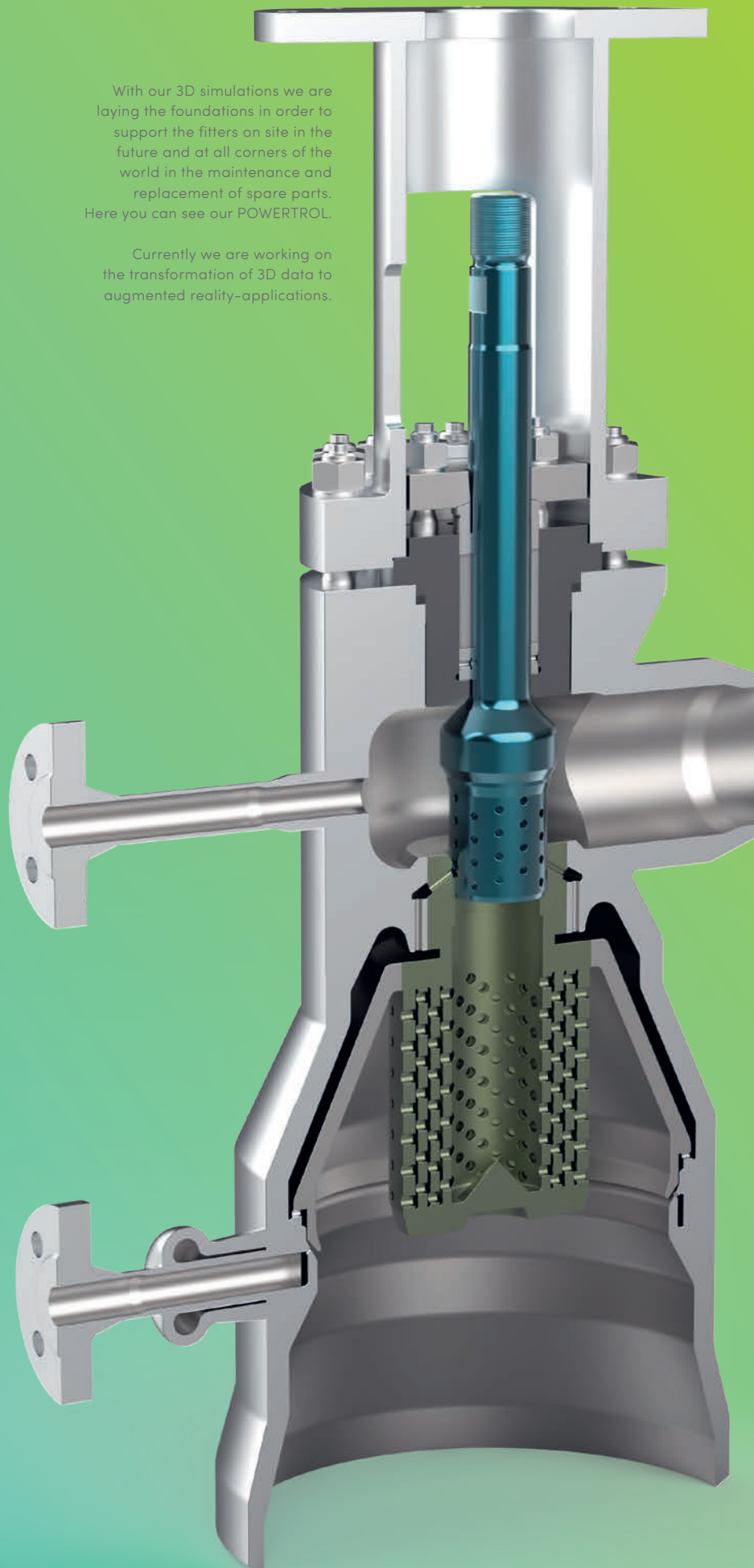

# ONE FOR ALL, ALL FOR ONE



The 500 worldwide employees of the ARCA Flow Group regard themselves as experts in process-supporting solutions. On the basis of outstanding engineer work and bold customer focus in Sales and Service, the international team of the ARCA Flow Group offers everything to guarantee the right “flow” of your processes the world over.

The culture which makes this performance promise of the ARCA Flow Group possible is based on the trust and respect that we show to every employee and on cooperation with confidence in each individual company and within the Group. Only in this way can there be responsibility for every individual for the greater good: the control of the processes that our customers entrust us with.

Everything so that the ARCA Flow Group can communicate a strong control promise:



## WE CONTROL THE FLOW





For reasons of better readability, we use the male form, e.g. "he".  
However, this always means all genders. The shortened form of speech is neutral.



# A CONTROL SOLUTION OF MANY:

## POWERROL

Series 580  
DN 15 – DN 800 / ½" – 32"  
PN 16 – PN 400  
Class 150 – 2500 temperature range  
-10 °C to 650 °C

**SERVICE-OFFER**  
**COMMISSIONING CHECK**

Design pursuant to EN 12952-10

Suitability as safety valve against pressure and temperature excess in SIL 2 applications

About the POWERROL video:



### Series 580

Our power product in the field of steam conditioning and cooling, for sophisticated uses and the highest safety standards

### Robust Housing

We design the valve for a long service life in demanding operation with high temperature gradients and frequent load changes

### ARCA ECO-Spray Nozzle

Our engineered 2-phase nozzle for the best possible cooling with short evaporation sections due to finest atomization of the cooling water

### Efficient Control

Our flow-optimized throttle bodies enable a stable control and the ultimate in noise reduction

