

Operating and maintenance manual
ARCAPAQ[®] pneumatic piston actuator
Series 812-DWK

Original instructions

© ARCA Regler GmbH. All rights reserved.

Cover picture background: Freepik.com

Table of contents

1	General data	5
1.1	Validity of the manual	5
1.2	Contact details.....	5
1.3	Other applicable documents.....	5
1.4	Place of storage of the manual.....	5
1.5	ARCA ONSITE	5
2	Safety	7
2.1	General safety information	7
2.2	Explanation of symbols and notices	7
2.3	Structure of the warning notices	7
2.4	Intended use.....	8
2.5	Inappropriate use	9
2.6	Use in potentially explosive areas (optional)	9
2.7	Residual risks	12
2.8	Qualification of the personnel.....	12
2.9	Operator's duty of care	13
2.10	Personal protective equipment.....	14
3	Transport, storage and packaging	15
3.1	Transport	15
3.2	Storage	15
3.3	Packaging.....	15
4	Nameplate	16
5	Type key	17
6	Sectional drawings	19
6.1	Parts list.....	19
6.2	812-****-DWK0.....	20
6.3	812-****-DWOK0.....	21
7	Functional description	22
8	Installation	23
9	Commissioning	24
9.1	Adjustment	24
9.2	Actuating signal connection.....	24
9.3	Positioner installation	25
10	Maintenance	26
10.1	Care.....	26
10.2	Maintenance.....	26
11	Disassembly / assembly of the actuator	27
11.1	Procedure	27

11.2	Guide and sealing element.....	27
11.3	Piston	27
11.4	Springs	28
12	Torque tables - bolted connections.....	29
12.1	Screws according to DIN EN ISO 4017/4014, DIN 939	29
12.2	Screws according to ASME B16.5	29
12.3	Sealing plug (39)	29
12.4	Bushing (4).....	29
12.5	Hex nut (18).....	29
13	Fault removal	30
14	Disposal and recycling	31

1 General data

This operating manual contains instructions that enable the product to be safely and properly installed, put into operation and maintained.

The target group for this operating manual is exclusively specially trained and authorised technical personnel.

Please contact the manufacturer if you encounter problems that cannot be solved with the aid of this operating manual.

The product is subject to technical changes at any time.

1.1 Validity of the manual

This operating manual applies to the product in the version described in the device pass.

1.2 Contact details

Further information about the product can be obtained from:

Manufacturer's address

ARCA Regler GmbH
Kempener Str. 18
D-47918 Tönisvorst
Tel.: +49 (0) 2156-7709-0
Fax: +49 (0) 2156-7709-55
E-mail: sale@arca-valve.com
www.arca-valve.com

1.3 Other applicable documents

The product can be delivered as part of an actuator and equipped with additional components that are described in their own operating manuals. The instructions as well as the warning and safety information contained therein must also be observed.

Furthermore, the following documents apply in addition to this operating manual.

- Device pass
- Installation drawing

1.4 Place of storage of the manual

The operating manual and all other applicable documents are part of the product. They must be kept in the immediate vicinity of the product and must be accessible to the personnel at all times.

1.5 ARCA ONSITE

Acceptance documents (if ordered) and operating documentation for this product can be downloaded from the ARCA ONSITE portal.

Two options are available here:

1. Scan the **QR Code**¹ on the product. Further entries are not required.

2. Visit the website <https://onsite.arca-valve.com/search> and enter the ARCA order no. and ARCA serial no. The order no. and serial no. can be found in the device pass and in our order confirmation.

Entry example

2512345	1234567
---------	---------

Search	Clear
--------	-------

[← back / zurück](#)

Illustration 1: ARCA ONSITE

¹ **QR Code** is a registered trademark of DENSO WAVE INCORPORATED

2 Safety

2.1 General safety information

The operating manual contains detailed descriptions for the safe installation, commissioning and maintenance of the product.

- Read this operating manual attentively in its entirety in order to familiarise yourself with the product.
- Particular attention must be paid to the information in this chapter.

2.2 Explanation of symbols and notices

Safety and warning instructions are intended to avoid hazards to the life or health of operating or maintenance personnel, and to avoid material damage. It is emphasised through the use of the special terms defined here. Additionally, their location is marked by warning symbols (pictograms). The signal terms used have the following meanings:



DANGER

means that death, serious injuries and/or considerable damage to property will occur if the corresponding preventive measures are not taken and maintained.



WARNING

means that death, serious injuries and/or considerable damage to property can occur if the corresponding preventive measures are not taken and maintained.



CAUTION

means that minor injuries and/or damage to property can occur if the corresponding preventive measures are not taken and maintained.



NOTICE

indicates an important item of information about the product itself or how the product should be handled, to which special attention should be paid.

2.3 Structure of the warning notices

Section-related warning notice

Section-related warning notices refer to the entire chapter, sections or several paragraphs within this operating manual. Section-related warning notices are structured as follows:



⚠ DANGER

Type and source of the danger

Possible consequences of disregard

- ▶ Measure to avoid the danger
- ▶ Further measures

Embedded warning notice

Embedded warning notices refer to a certain area within a section. They apply to smaller information units than the section-related warning notices. Embedded warning notices are structured as follows:

⚠ DANGER! Instructions for avoiding a dangerous situation.

2.4 Intended use

The product complies with laws, regulations and standards valid at the time of delivery.

The product does not pose a danger to people, property or environment if it is used for its intended purpose and the warning notices contained in this operating manual and attached to the product are observed. This applies to the entire lifetime, from the delivery, assembly and operation to the disassembly and disposal.

The following is deemed to be used for the intended purpose:

- Operate the product exclusively in accordance with this operating manual and in accordance with the specification in the order confirmation and the device pass.
- Use exclusively original ARCA spare parts for the maintenance of the product.



⚠ DANGER

Risk of death and serious injuries as well as damage to property and the environment!

Risk of death and serious injuries as well as damage to property and the environment due to hazardous operating media, high temperatures and pressures as well as moving parts.

- ▶ The following requirements and conditions must be complied with without fail.
- ▶ Observe warning notices.

Maintenance

Ensure or observe the following before performing any maintenance work:

- Depressurise the actuator and the attached valve.
- If necessary, cool the actuator down or heat it up to ambient temperature.
- Disconnect electrical connections, if any.
- The actuator springs are inserted with a high preload; it is imperative to follow the disassembly instructions according to the chapter entitled Diaphragm.
- Ensure that the system cannot be started up by third parties.

- You are expressly directed to observe the regulations for potentially explosive equipment where necessary. Refer also to the chapter Use in potentially explosive areas (optional).

Limits of use

Operate the actuator only within the following limits of use.

Max. operating pressure [bar]	Min. operating temperature [°C]	Max. operating temperature [°C]
6	-20 / Low temperature version -40	+80

The actuator is designed for a maximum number of switching cycles of 1 million full strokes.

The max. permissible switching cycle frequency is 1 full stroke per second.

2.5 Inappropriate use

Inappropriate use is use of the product other than as described in the chapter entitled [2.4] *Intended use*.

In the addition, the following applies:

- Unauthorised modifications to the product can lead to injuries, damage to property and malfunctions. The user alone bears this risk. Warranty and liability claims are excluded.

2.6 Use in potentially explosive areas (optional)

The product can also be used in potentially explosive areas if fitted with the **optional** additional "EX" equipment.



⚠ WARNING

Unsuitable product for potentially explosive areas

Risk of explosion!

- ▶ Use only products that are approved for use in Ex-zones and are marked accordingly.
- ▶ Make sure that the product is suitable for the area of use.



⚠ WARNING

Impermissible accessories and impermissible spare parts

Risk of explosion or damage to the product!

- ▶ Use exclusively original accessories and original spare parts.
- ▶ Observe all relevant installation and safety instructions described in the manuals for the product, accessories and spare parts.



⚠ WARNING

Exceeding the maximum ambient or media temperature

Risk of explosion due to high surface temperature!

The temperature class of the product is no longer valid if the maximum permissible ambient or media temperature is exceeded!

- ▶ Make sure that the maximum permissible ambient or media temperature of the product is not exceeded.



⚠ WARNING

Contaminated operating medium

Risk of explosion and damage to the product due to clogging up with fine dust or solid contents!

- ▶ Install a pre-filter or fine filter
- ▶ Clean the filter after 100,000 switching cycles or at least twice annually.



⚠ WARNING

Heat radiation

Risk of explosion due to high surface temperature as a result of heat radiation from additionally attached products!

- ▶ Make sure that the maximum permissible surface temperature is not exceeded.
- ▶ Insulate or decouple any attached products that radiate increased heat.



⚠ WARNING

Dust deposits

Risk of explosion due to raised product temperature as a result of dust deposits!

- ▶ Remove dust deposits that are thicker than 2 mm.
- ▶ Avoid electrostatic charging of the surface; remove dust deposits properly without rubbing the surface.



⚠ WARNING

Damaged surface coating

Risk of explosion due to damage to the surface coating in conjunction with corrosion and aluminium!

- ▶ Make sure that the surface coating is not damaged and that there is no corrosion.



⚠ WARNING

Exceeding the layer thickness of the surface coating

Risk of explosion due to electrostatic charging of the electrically non-conductive surface coating!

- ▶ Make sure in case of overpainting that the surface coating does not exceed a total thickness of 0.2 mm.



⚠ WARNING

External impact effect

Risk of explosion due to generation of sparks caused by an impact!

- ▶ Avoid external impact effects on the product.



⚠ WARNING

Dismantling the product

Risk of explosion due to the ingress of an explosive atmosphere!

- ✓ The product may only be opened after it has been proven that no explosive atmosphere exists in the area around the product
- ▶ Ensure through ventilation that there is no explosive atmosphere. If this is not possible, take the product to an area where there is no risk of explosion.



⚠ WARNING

Non-conductive materials with pipe-laying work

Risk of explosion due to potential differences when using non-conductive materials!

- ▶ When using non-conductive materials for piping or sealing, care must be taken that they are bridged with conductors.



⚠ WARNING

Non-conductive lubricants

Risk of explosion due to potential differences when using non-conductive lubricants!

- ▶ Use only electrically conductive lubricants to lubricate the components.



⚠ WARNING

Exceeding the max. surface temperature at bearing points

Risk of explosion due to raised surface temperature in case of inadequate lubrication and dust deposits at the bearing points!

- ▶ Make sure that the maximum permissible surface temperature is not exceeded.
- ▶ The lubrication and dust deposits at the bearing points must be inspected after 100000 operating cycles or at least twice annually.

ATEX nameplate

Illustration 2: ATEX nameplate

1	Manufacturer
2	Type designation
3	ATEX marking for gas atmosphere
4	ATEX marking for dust atmosphere
5	Serial no.
6	"X" marking – the actuator can be used for an ambient temperature of -40 °C up to a surface temperature of +80 °C.
7	"X" marking – the actuator can be used for an ambient temperature of -40 °C up to a surface temperature of +80 °C.

2.7 Residual risks

There may still be residual risks even if the product is used for its intended purpose.

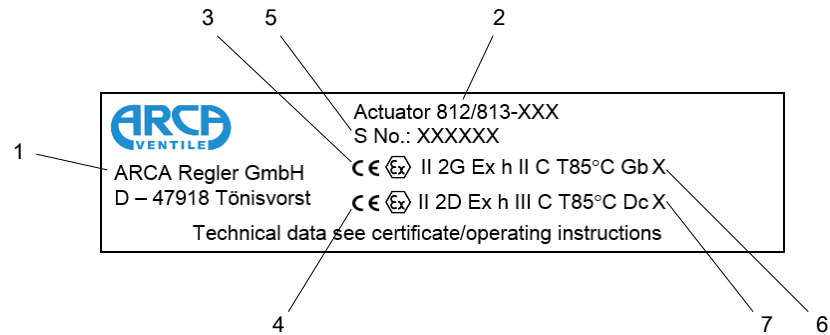
- Danger of being crushed by unsecured actuators

In case of negligent use of personal protective equipment:

- Danger due to noise resulting in hearing loss
- Thermal hazards (burning, scalding, etc.)
- Danger due to escape of the operating medium

Furthermore, there may be unapparent residual risks despite all precautions taken.

Residual risks can be minimised if the notes on safety and commissioning as well as the operating manual as a whole are observed.

2.8 Qualification of the personnel

The product is exclusively intended for use in plants and installations in which trained technical personnel carry out the necessary work. Technical personnel are persons who are entrusted with the installation, commissioning and operation of this product and who have the appropriate qualifications for their work activities, such as, for example:

- training or instruction in accordance with current technical safety standards in the maintenance and usage of appropriate safety equipment.
- Training in First Aid.

- In the case of systems with explosion protection: training or instruction and authorisation to carry out work on potentially explosive systems.

Repair work may be carried out only by trained and qualified technical personnel.

Work on electrical equipment may be carried out only by trained electricians or persons who have received electrotechnical instruction.

Persons	Instructed persons	Persons with a recognised technical education	Persons with a recognised electrotechnical education	Superiors with relevant skills	ARCA service personnel
Activity					
Transport	X	X	X	X	X
Installation	X	X	X	X	X
Commissioning		X	X	X	X
Maintenance	X	X	X	X	X
Fault finding		X	X		X
Mechanical troubleshooting		X			X
Electrical troubleshooting			X		X
Repairs		X	X	X	X
Disposal	X	X	X	X	X

2.9 Operator's duty of care

To avoid accidents, malfunctions and environmental impacts, the respective person responsible for the transport, commissioning, operation, maintenance and disposal of the product must ensure the following:

- Observation of all warning and danger notices.
- Regular instruction of personnel on all applicable questions of work safety, the operating manual and in particular the safety instructions that it contains.
- Regulations and work instructions for safe working as well as the corresponding instructions for the conduct of the personnel in case of accidents and fire are to be kept at the ready at all times and hung up in the plant if necessary.
- Operate the product only if it is in perfect working order.
- Use only spare parts, lubricants and operating resources approved by the manufacturer.
- Observe the specified operating conditions and requirements at the place of installation.
- Provide all necessary devices and the personal protective equipment required for the respective task.
- Refer to the chapter entitled Maintenance for the prescribed maintenance intervals and comply with the corresponding regulations.
- Allow installation, commissioning and maintenance of the product to be carried out only by qualified and trained personnel in accordance with this operating manual.

- The operator must ensure that the product is used for its intended purpose.
- Before commissioning the product the operator must carry out a risk assessment and define appropriate inspection and maintenance intervals according to the operating conditions.

2.10 Personal protective equipment

Personal protective equipment must be worn during work in order to minimise health risks.

- During work, always wear the protective equipment necessary for the respective work
- Follow the notices about personal protective equipment displayed in the working area.

Always wear	
	<p>Protective clothing</p> <p>Tight-fitting work clothes with a low tear resistance, with narrow sleeves and without protruding parts. They primarily serve to protect against being caught up by moving machine parts.</p> <p>Do not wear rings, chains or other jewellery.</p>
	<p>Safety shoes</p> <p>To protect against heavy falling parts and slipping on smooth floors.</p>

Wear in case of particular environmental conditions	
<p>Special protective equipment is necessary in particular environmental conditions.</p> <p>It is to be selected according to the environment.</p>	
	<p>Safety glasses</p> <p>To protect the eyes against flying parts and splashes of liquids.</p>
	<p>Helmet</p> <p>To protect against falling and flying parts and materials.</p>
	<p>Hearing protection</p> <p>To protect against hearing damage.</p>

3 Transport, storage and packaging

3.1 Transport



WARNING

Tipping or falling load!

Danger of death and danger of damage to property due to load tipping over or falling!

- ▶ Only suitable and approved means of transport and lifting equipment may be used for transporting the product.
- ▶ Lifting equipment must generally be attached to the housing of the product, not to attachments.
- ▶ Allow only instructed persons to select and attach the lifting equipment.
- ▶ Do not stand under suspended loads.

Transport at a temperature lower than -40 °C or higher than $+80\text{ °C}$ is not permissible.

The attachment points on actuators (lifting eyes, ring bolts, etc.) are designed solely for transporting the actuator. Under no circumstances may these attachment points be used if the actuator is coupled to a valve.

3.2 Storage



NOTICE

Improper storage!

There is a danger of the product and in particular the attached electronic accessories no longer functioning if stored improperly.

- ▶ Storage at a temperature lower than -40 °C or higher than $+80\text{ °C}$ is not permissible.
- ▶ It must be stored in roofed-over storage places and that are weather-proof.

To protect against contamination and to protect the sealing surfaces, openings such as nozzles, flanges, etc. must be sealed using suitable means. These should be removed by technical personnel at the place of installation.

3.3 Packaging

The product is packed in a PE film inside the outer packaging (cardboard box, wooden crate, pallet, lattice box).

If the packaging, in particular the PE film, has been opened, the product must be stored immediately in a heated room.

The product must be packed in weatherproof or seaworthy packaging for transport by ship, airplane, rail or truck.

4 Nameplate

Type:	1					
DN:	2					
PN:	3	Stroke:	4	mm	Order-No.:	6
Material:	5				Serial-No.:	9
KVs:	7	Seat-Ø:	8	mm		
Actuator:	10					
Spring-Range:	11				bar	
Air-Supply:	12				- max. 6 bar	
Security Position:	13					
TAG/KKS-No.:	14					
Manufacturer:	ARCA-Regler GmbH		15		Construction year:	16



Illustration 3: Nameplate

1	Type designation valve
2	Nominal size
3	Nominal pressure
4	Valve stroke
5	Material of housing / trim
6	ARCA order number
7	Flow coefficient, characteristic curve
8	Seat diameter
9	Serial number
10	Actuator type code
11	Actuation pressure range
12	Max. actuation pressure
13	Valve safety position
14	Marking
15	Conformity mark
16	Year of manufacture

Place of installation

The nameplate is attached to the actuator yoke or the actuator head.

5 Type key

812	-	2	2	3	_	N	-	DWK	0
[1]		[2]	[3]	[4]	[5]	[6]		[7]	[8]
1. Series									
812									
2. Actuator size									
2 MFI piston area 284 cm ²									
3. Yoke (Ø = mounting in mm)									
0 without									
1 Ø40									
2 Ø48									
3 Ø56									
9 Special version									
4. Stroke									
3 20 mm									
4 30 mm									
5. Spring set									
_ no springs									
3 3 springs									
6 6 springs									
6. Diaphragm head / yoke material									
N Steel / Steel									
A Steel / Stainless steel									
V Stainless steel / Stainless steel									
7. Function									
DWK Double-acting									
DWOK Double-acting with safety position "closed"									
8. Additional equipment									
0 none									
4 Low temperature version max. -40°C (incl. 6)									
5 Air connection G ¹ / ₂									
6 Screws, stainless steel (long)									
AP External stainless steel parts, passivated (incl. 6)									
EX Explosion-proof version									
SD Stem 1.4462 (incl. 6)									
X Peripheral bolts XYLAN									
Z Peripheral bolt ASME									

Example of type designation 812-223 N-DWK-0

MF1 pneumatic piston actuator – mounting diameter 48 mm – stroke 20 mm – diaphragm head / yoke material steel / steel – double-acting function – no additional equipment.

6 Sectional drawings

Some versions of the actuator are illustrated below. Further versions are possible by combining the different components.

Connections

Z1, Z2, Z3 see [9.2] *Actuation signal connection*

6.1 Parts list

Item	Name
1	Stem
2	Pin
3	* Sealing ring
4	Bushing
5	* Plain bearing
6	* O-ring
7	Filter
14	* Compression spring
18	* Hex nut
21	Hex screw
22	Washer
23	Hex nut
24	* Sealing
25	Screw sleeve
26	* O-ring
28	* O-ring
29	Sealing plug
30	Stroke plate
31	Cylinder head bolt
32	Washer
34	Lantern
38	* Sealing
39	Sealing plug
43	* Pipework, compl.
46	Thread adapter
47	Nameplate Ex
69	* O-ring
76	Intermediate ring
77	Piston
78	* Guide band
79	* Sealing ring
108	bottom cover
118	top cover
119	Washer
	* recommended spare part / wearing part

6.2 812-**-DWK0**
 Function: Double-acting

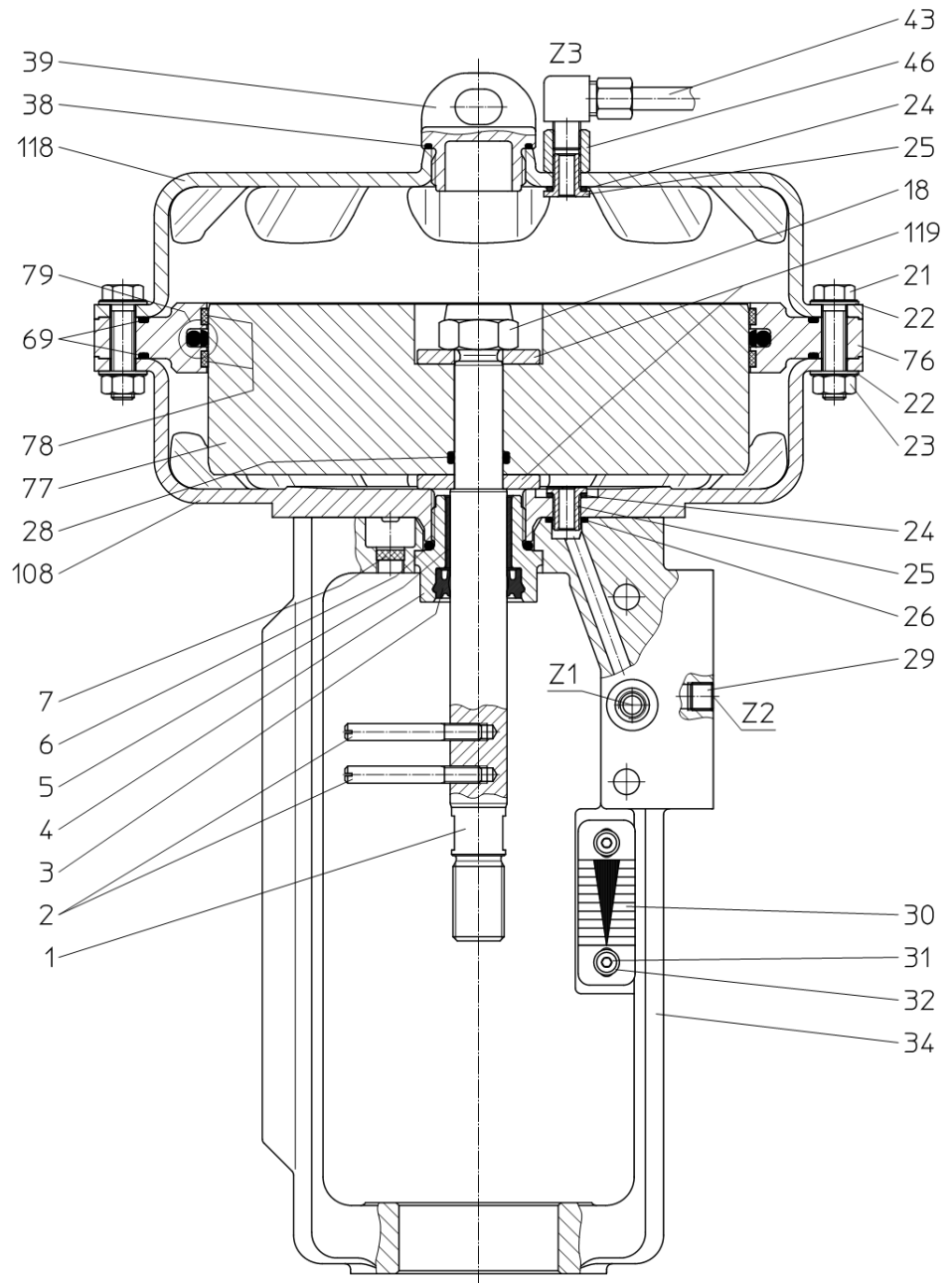

Illustration 4: 812-****-DWK0

6.3 812-**-DWOK0**

Function: Double-acting with safety position "closed"

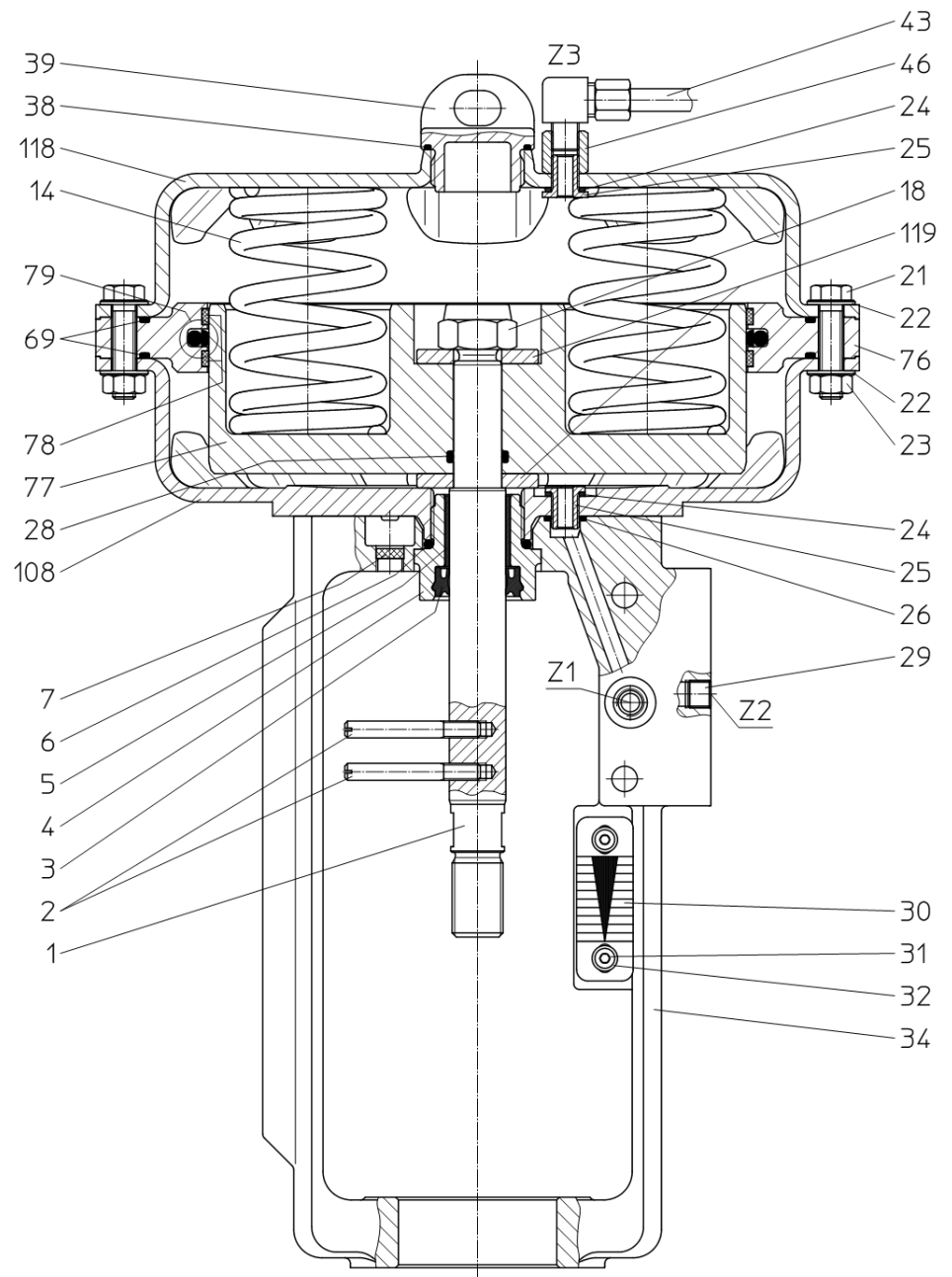

Illustration 5: 812-****-DWOK0

7 Functional description

The series 812-DWK has been developed as a double-action, pneumatic piston actuator for linear valves. The centrally located actuator stem (1) is coupled to the actuating spindle of the valve by means of a coupling.

The actuator stem (1) is precisely guided by a plain bearing (5) and the lower pressure chamber is sealed by a special sealing element with a wiper (3). Connected to the actuator stem (1) is a piston (77), which transmits the movement to the actuator stem (1). An intermediate ring (76) with a sealing ring (79) divides the actuator housing (108, 118) into the two pressure chambers. If the pressures in the pressure chambers are different, the piston (77) moves together with the actuator stem (1) and actuates the linear valve.

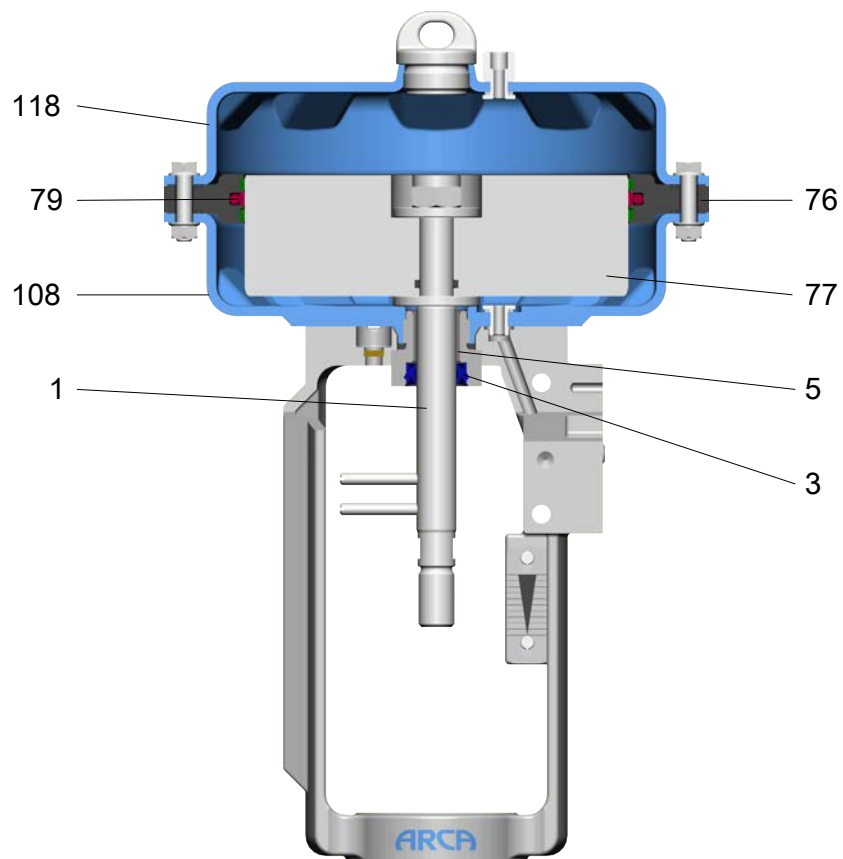

Illustration 6: Sectional drawing

8 Installation

Place of installation

The actuator should be easily accessible from at least one side and from above.

Include a catwalk or similar in the planning in case of greater heights.
An electric crane or block and tackle should be provided if necessary.

Installation

The actuator yoke (34) has a central bore that enables rotation of the actuator in any direction. The actuator is fastened to the valve with the slotted nut of the valve. Actuator and valve are coupled to each other via a stroke indicator.

The maximum permissible actuating forces of the valve must be observed.

Mounting position



Please note:

CAUTION

Mounting position

- ▶ Pipeline horizontal
- ▶ Actuator housing above the valve
- ▶ Align the actuator and attached parts to the valve

Please consult us in case of a different mounting position!

9 Commissioning

9.1 Adjustment

Stroke adjustment

- **⚠ CAUTION!** Shear forces must not be transmitted to the actuator stem (1) when coupling actuator and valve.
- **⚠ CAUTION!** Do not turn the actuator stem (1) in a radial direction.
 - The pins (2) must lie in the transverse axis of the yoke (34) as shown in the sectional drawing.
- **NOTICE!** Adjust the stroke so that the closing position of the valve is not hindered by the internal, non-adjustable stroke limiter of the actuator.

9.2 Actuating signal connection

Air quality

⚠ CAUTION! Ensure correct air quality!

Oil-free, instrument-quality air with no water or dust, solid material content max. 1 mg/m³ (standard atmospheric conditions), max. particle size 0.1 mm, oil content max. 1 mg/m³ (standard atmospheric conditions), pressurised dew point 20 K below the lowest ambient temperature.

When working on the compressed air system ensure that any contamination present such as water, oil, chips, soldering material residues, etc. are expelled by blowing out.

Air connections

The actuator has air connections (Z...) with an internal thread.

Actuator size	Connection Z1	Connection Z2	Connection Z3
MFI	G 1/8	G 1/8	G 1/8 *

* G 1/2 alternatively also possible.

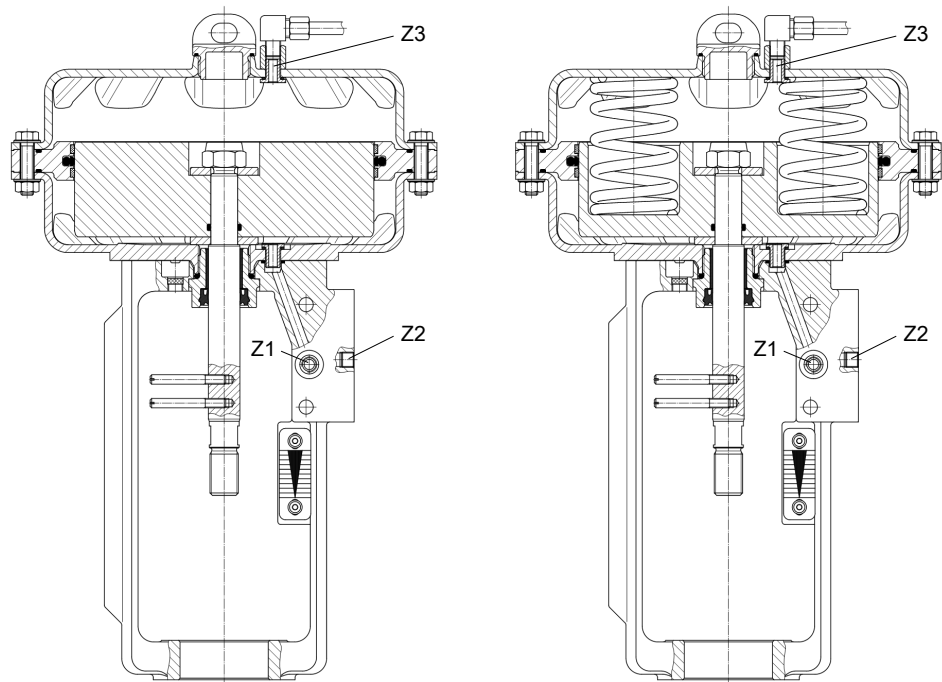

Illustration 7: Air connections

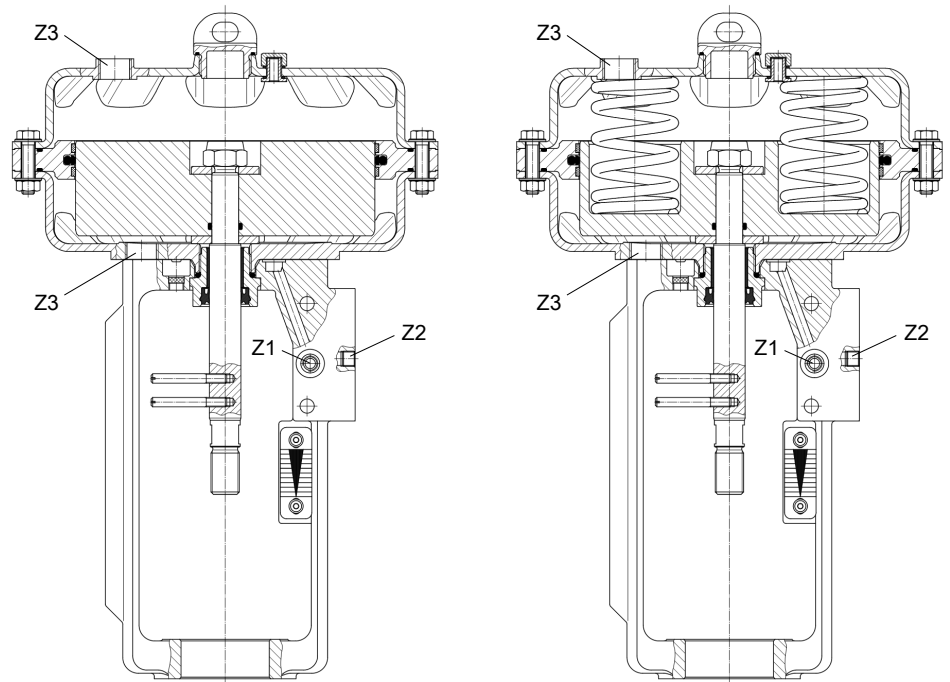

Illustration 8: Air connections with additional equipment Z3 G ½

Standard

- Seal connection "Z1" on the yoke (34) with a plug.
- Connect the air supply pipe to the connections "Z2" on the yoke (34) and "Z3" on the top cover (118) with the aid of screw connections.

When using a positioner (integrated installation)

- Seal connection "Z2" on the yoke (34) with the plug (29).
- Connect the positioner in accordance with the operating manual.

9.3 Positioner installation

Integrated installation of positioners

The actuation signal connection and feedback lever take place directly when fitting the positioner. Refer to the operating manual for the respective device for the mounting instructions.

Installation according to IEC 534 (NAMUR)

The actuator yoke (34) is designed on the basis of the directive IEC 534 Part 6 (NAMUR) and enables the attachment on one side of auxiliary devices with an M8 fastening thread.

10 Maintenance

10.1 Care

- Clean the actuator stem (1) if necessary
 - Clean the actuator stem (1) of adhering dirt using a soft cloth

NOTICE! Never use sandpaper, since this will damage the surface of the stem and reduce the lifetime of the stem sealing.

10.2 Maintenance

The actuator requires almost no maintenance.

Nevertheless, the connections must be checked after 100,000 operating cycles or twice per year for leaks.

In addition it is necessary to check and clean the gliding surfaces.

Depending on the operating conditions of the actuator, the operator is responsible for defining appropriate inspection and maintenance intervals.

11 Disassembly / assembly of the actuator



WARNING

Disregarding the safety instructions

Risk of injury!

- ▶ Observe the notes in the chapter entitled [2] *Safety*

11.1 Procedure

- Disassembly in the given order.
 - Dismounted parts are to be secured carefully against falling down (risk of injury or damage).
- Clean all components.
- Before assembly, all components must be inspected for damage or wear and replaced where necessary.
- Assembly in the reverse order using the new components.
 - Seals must generally be replaced.
 - Insert O-rings and shaped rings with a suitable lubricant.
 - Refer to the chapter entitled [12] *Torque tables* for the tightening torques of bolted connections.

Recommended lubricants

O-rings, shaped rings, guide bands	Bolted connections	Roller bearing
Molykote 55	Metaflux lubricating metal paste 70-85	Shell Retinax Grease EP2

11.2 Guide and sealing element

- Remove the stroke indicator
- Remove any positioner if fitted
- Unscrew the pins (2)
- Unscrew and remove the complete bushing (4)
- Observe the following during the assembly:
 - Observe the notes in the chapter [9.1] *Adjustment!*

11.3 Piston



DANGER

Danger of death and serious injuries as well as damage to property due to high spring preload!

If the following instructions are disregarded, serious injuries resulting in death as well as severe damage to property cannot be ruled out.

- ▶ It is imperative to follow the instructions and the given order below
- ▶ Observe warning notices

"DWK" function

- Remove any positioner if fitted

- Loosen the screws (21)
- Remove the top cover (118)
- Remove the intermediate ring (76)
- Replace the sealing ring (79), guide band (78) and O-rings (69)
- Remove the piston (77) with the stem (1)

"DWOK" function

- Remove any positioner if fitted
- Dismount 4 hex nuts (23) and bolts (21) **evenly** at the periphery.
- Mount assembly/disassembly bolts (21) in grade 8.8 and new hex nuts (23) in grade 8.8.
 - **NOTICE!** The assembly/disassembly bolts (21) and nuts (23) in grade 8.8 are not part of the scope of delivery!

Actuator size	Bolt size
MFI	M8 x 50

- Loosen the hex nuts (23) of the short bolts (21)
- Loosen the hex nuts (23) of the newly mounted assembly/disassembly bolts (21) **evenly** in order to relax the springs (14).
- Remove the top cover (118)
- Remove the compression springs (14)
- Remove the intermediate ring (76)
- Replace the sealing ring (79), guide band (78) and O-rings (69)
- Unscrew the pins (2)
- Remove the piston (77) with the stem (1)

11.4 Springs

- Disassembly according to [11.3] *Piston* chapter up to removal of the compression springs (14).
- Replace the compression springs (14) by new compression springs.
 - **CAUTION!** Always replace the compression springs as a complete set! Observe the arrangement of the compression springs (14)!

Mounting position

Number of springs	Mounting at position
2	1 + 4
3	1 + 3 + 5
4	2 + 3 + 5 + 6
6	1-6

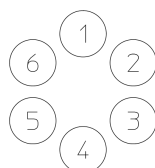

Illustration 9: Spring arrangement

12 Torque tables - bolted connections

12.1 Screws according to DIN EN ISO 4017/4014, DIN 939

Thread	Torque [Nm]	
	A4-80	8.8
M6	7	8
M8	30	30

12.2 Screws according to ASME B16.5

Thread	Torque [Nm/lbf ft]	
	A193B8	A193B7
1/4"-UNC	7/5	8/6
5/16"-UNC	30/22	30/22

12.3 Sealing plug (39)

Actuator size	Torque [Nm]
MFI	40

12.4 Bushing (4)

Actuator size	Torque [Nm]
MFI	170

12.5 Hex nut (18)

Actuator size	Thread	Torque [Nm]
MFI	M16	120

13 Fault removal



⚠ WARNING

Improper troubleshooting work

Risk of injury!

- ▶ For all troubleshooting work, observe the corresponding notes – in particular the safety instructions – in this operating manual or in the operating manuals for the additionally installed components.

Please contact the manufacturer if problems occur that are not described in this table.

Fault	Possible causes	Action
Actuator stem doesn't move	No actuation air pressure signal present	Check signal source
	Actuation signal connection incorrectly implemented	Check actuation signal connection and direction of action of the actuator
	Actuation signal air pressure too low	Increase air pressure, observe max. permissible air pressure
	Piston seal defective	Replace the piston seal
Actuator stem seal is leaking	Sealing element worn	Replace sealing element, clean stem surface
	Stem surface damaged	Replace stem and sealing elements
Actuating force too low	Actuation signal air pressure too low	Increase air pressure, observe max. permissible air pressure
	Leaks in the actuation signal line	Check the signal line
	Positioner, if any, is incorrectly adjusted	Check the positioner adjustment

14 Disposal and recycling



DANGER

Danger of death and serious injuries as well as damage to property due to high spring tension!

If the following instructions are disregarded, serious injuries resulting in death as well as severe damage to property cannot be ruled out!

- ▶ The actuator may only be disposed of with the actuator springs removed
- ▶ Remove actuator springs before disposal
- ▶ Strictly follow the disassembly instructions



WARNING

Operating media and auxiliary materials that are hazardous to health

Danger to people and the environment!

- ▶ Wear suitable protective equipment
- ▶ If applicable, collect and dispose of rinsing medium or residual medium. Particular attention is to be paid to dead spaces (pressure compensation, bellows, etc.)
- ▶ Observe the legal regulations for the disposal of media that are hazardous to health

ARCA products are modularly constructed and can be sorted by material into the following components.

- Electronic components
- Metals
- Plastics
- Greases and oils
- Packaging material

The general rules are:

- greases and oils are usually water pollutants and must not be allowed to escape into the environment
- Dispose of dismantled materials properly or recycle the separate materials
- Observe national disposal regulations



www.arca-valve.com